



COMBAC

badrum



EN 14428:2015+A1:2018

MONTERINGSANVISNING

ELLA



Classical design



Comfortable to bath and optically nice height



Strong and stable construction



Fixation of closed doors



Good tightness



Strong fixation of opened doors



Function of door lifting



Function of regulation of door's angle



Easy maintenance

SV *Innan duschväggarna installeras är det nödvändigt att se till att el- och vatteninstallationer som finns i väggar och i golv inte skadas. Du är ansvarig för sådan skada. *Dessutom är det nödvändigt att rengöra installationsplatsen samt glaset med glasrengöring. *Använd endast sanitetssilikon för installation. *Glaset som finns i förpackningen måste skyddas från direkt kontakt med kakel eller keramik. När de är upppackade kan de läggas på kartong. *Undvik plötsliga eller häftiga rörelser när du reser glaset. *Alla installationsarbeten måste utföras enligt instruktionerna så att duschväggarna i slutändan är kvalitativa och läckagesäkra. *Alla mått i instruktionen anges i millimeter. *Innan du börjar montera duschväggarna är det viktigt att inspektera kvaliteten på materialen: huruvida glas, profiler och duschglas inte är repade eller skadade. Tillverkaren accepterar inte några anspråk avseende sådana skador om installationen av produkten redan har påbörjats eller slutförts. *Eventuellt sneda väggar eller golv bör tas i beaktande innan installation.

EN *Before the shower panel is installed, it is necessary to make sure that electric and water installations present in the walls and in the floors will not be damaged. You shall be responsible for such damage. *Besides, it is necessary to clean the installation place and glasses using the glass cleaner. *Use only sanitary silicone for installation. *The glasses present in the package must be protected from direct contact with tiles or ceramics. When unpacked, they may be put on carton sheet. *Avoid sudden or strong movements, while erecting the glass. *All the installation works must be performed consistently with instruction so that in the end the shower panel is qualitative and leakage-proof. *All the dimensions in the instruction are provided in millimetres. *Before starting to assemble the enclosure, it is necessary to inspect quality of materials: whether the glass, profiles and shower fittings are not scratched or damaged. The manufacturer shall not accept any claims regarding such damages if installation of the panel has been already started or completed. *The straightness of walls and floors has to be assessed before the installation and it has to be taken into account in the course of panel's installation.



Tack för att du valde vår moderna mönster-dusch ELLA. Det nya och unika mönstret ger en spännande intryck.

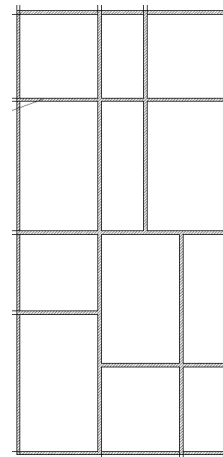

Combac är en del av;

inreda
bad & interiör

inreda bad & interiör AB info@inredabadointerior.se +46 512 50060 www.inredabadointerior.se



facebook.com/inredabadointerior



instagram.com/inredabadointerior

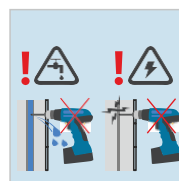
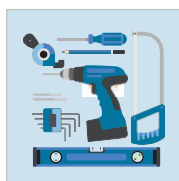
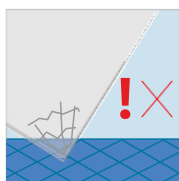

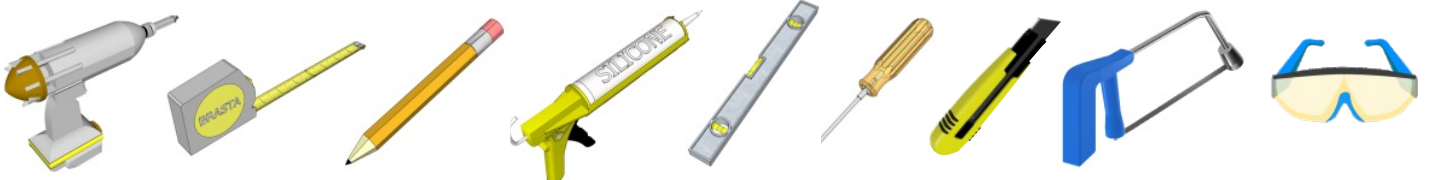
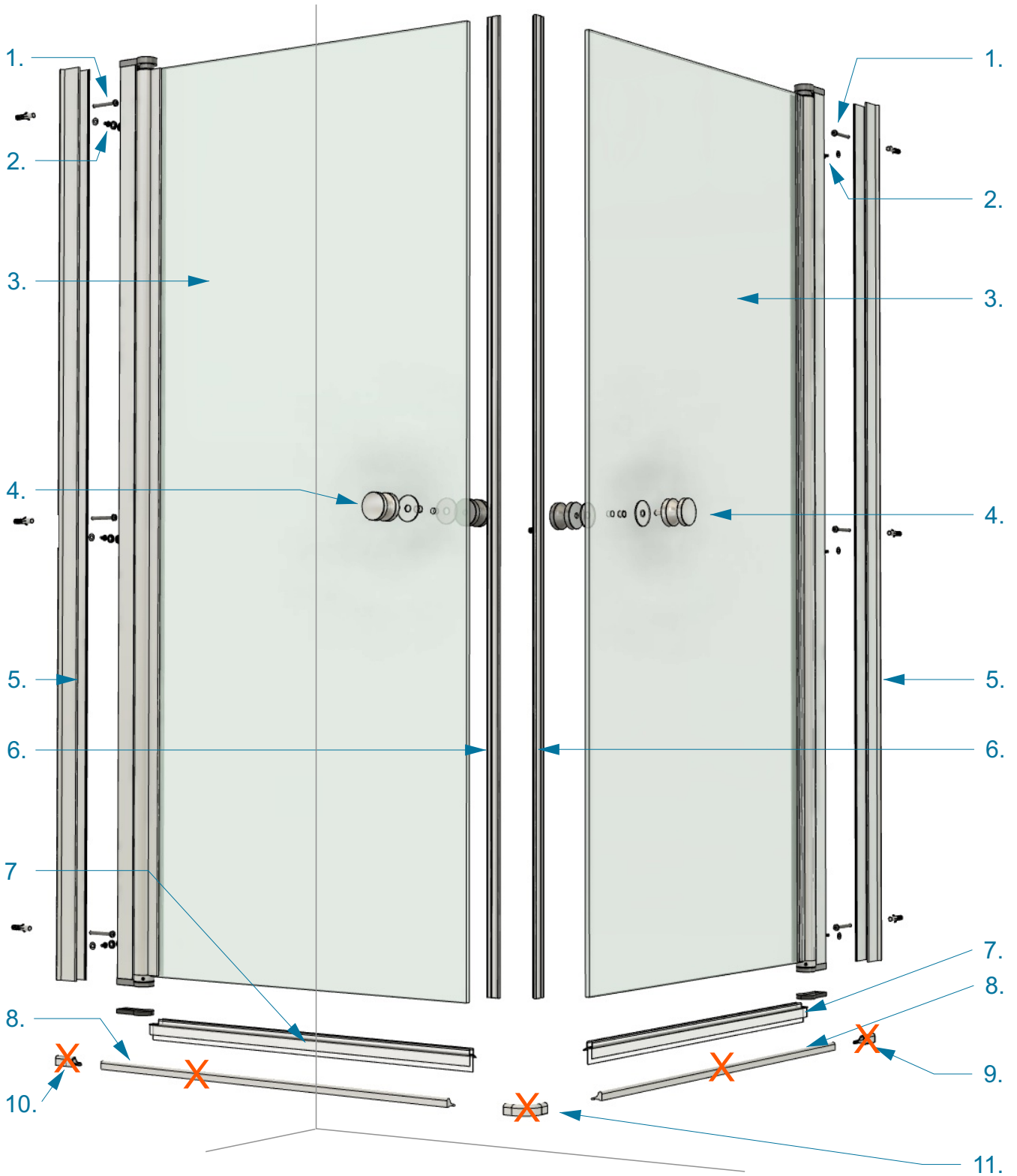

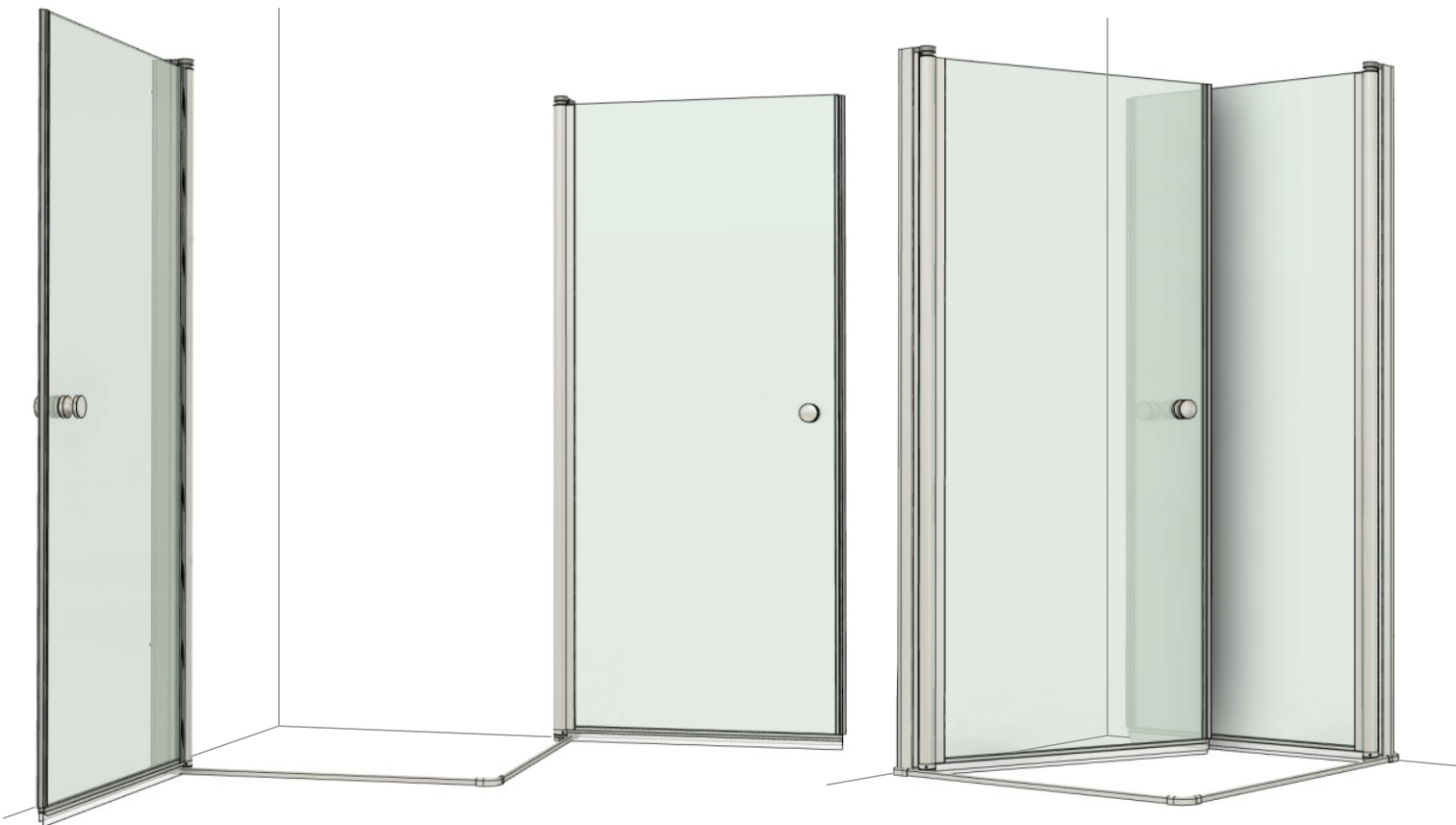
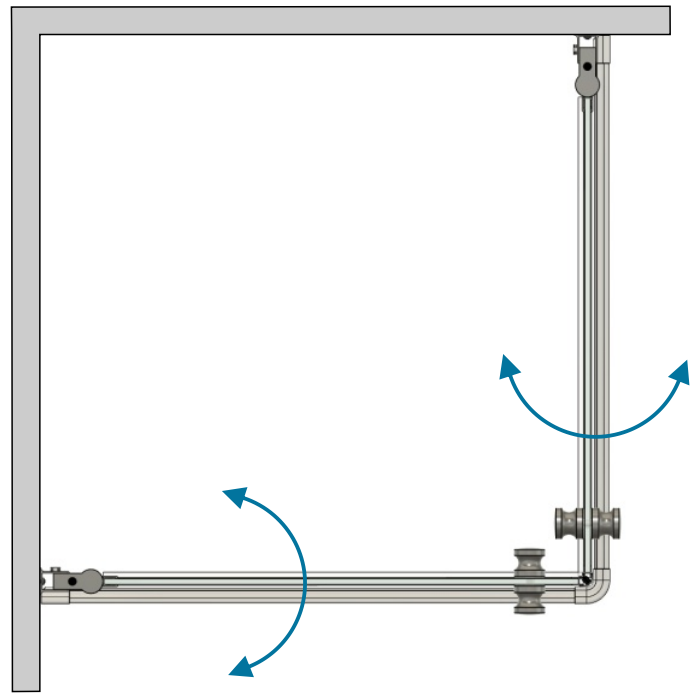

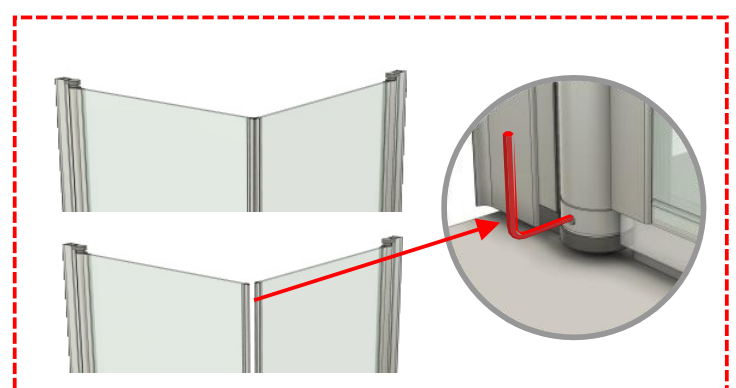
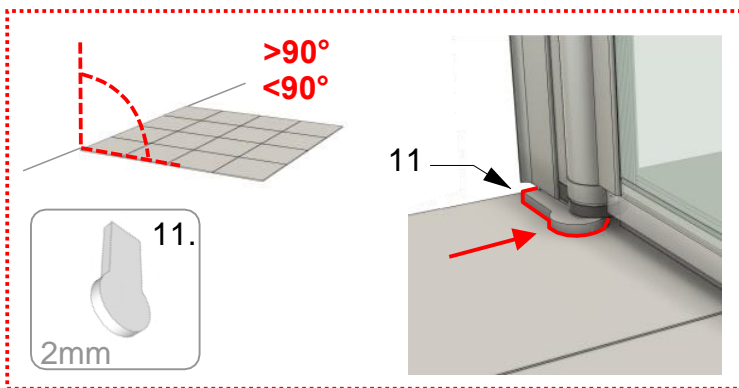
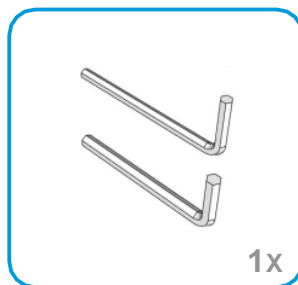
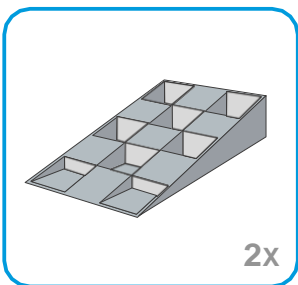
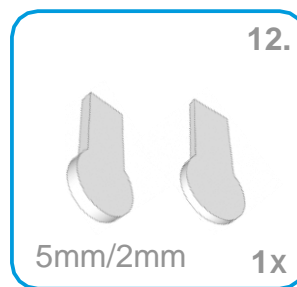
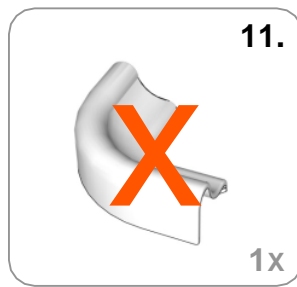
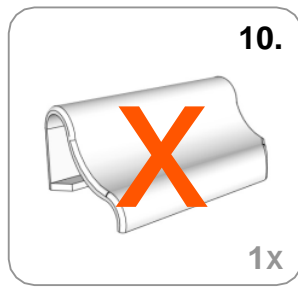
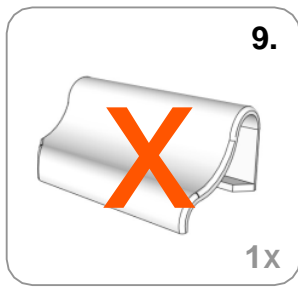
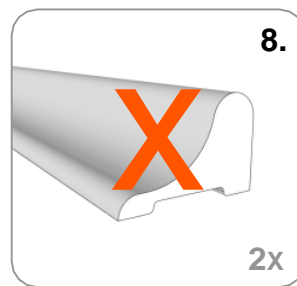
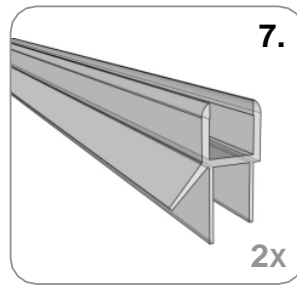
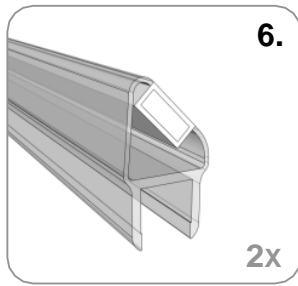
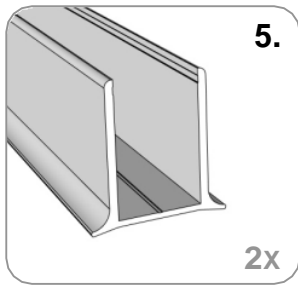
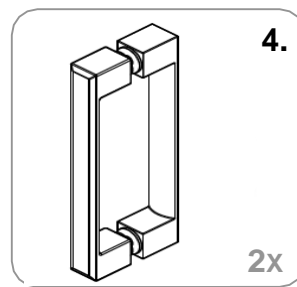
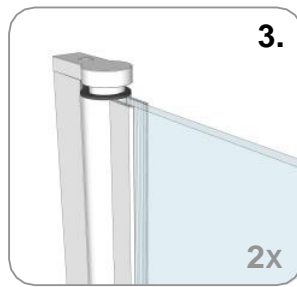
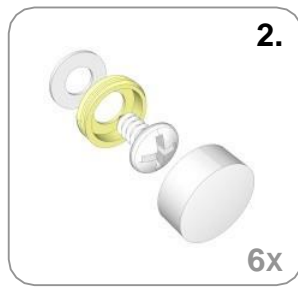
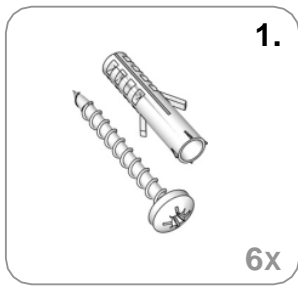

1.

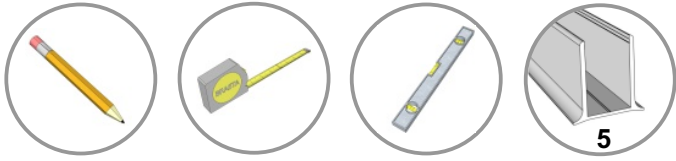

Kartong

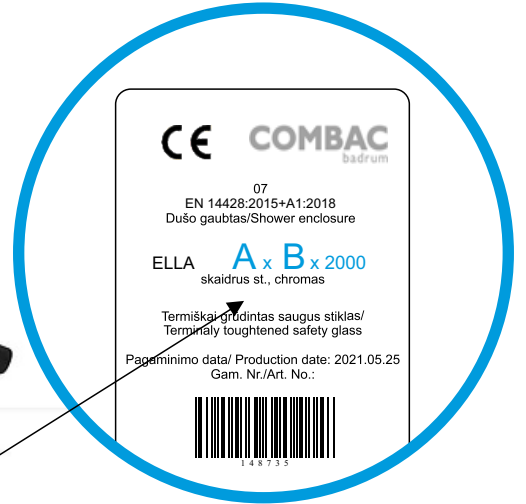
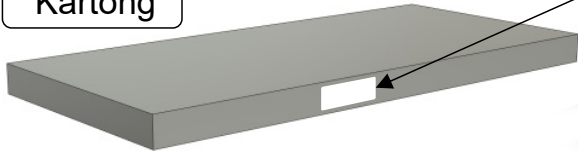

A

80x80 (775-788; 775-788) mm
90x90 (875-888; 875-888) mm
100x100 (975-988; 975-988) mm

B

80x80 (775-788; 775-788) mm
90x90 (875-888; 875-888) mm
100x100 (975-988; 975-988) mm

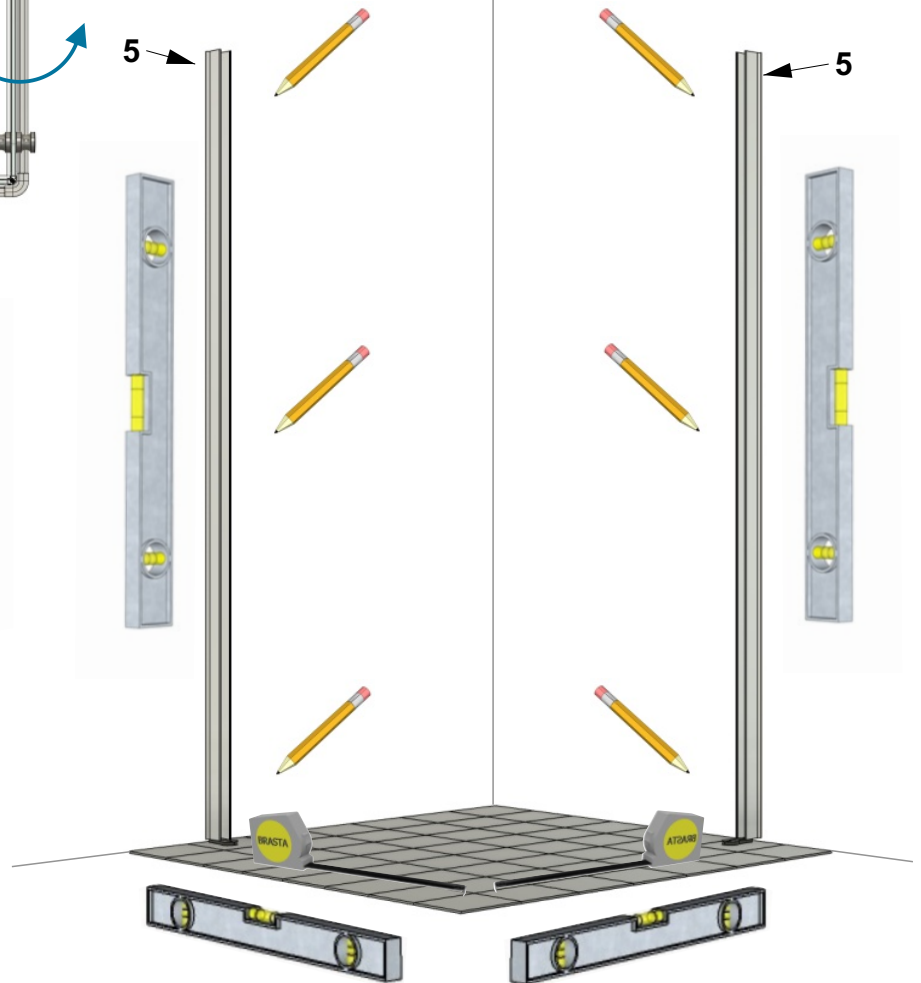
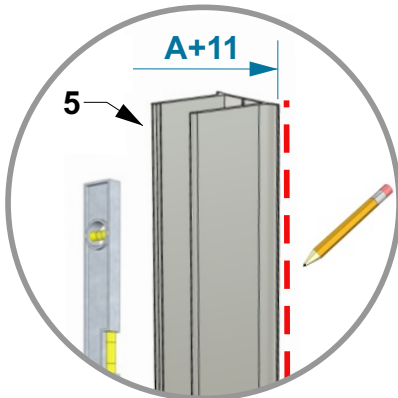
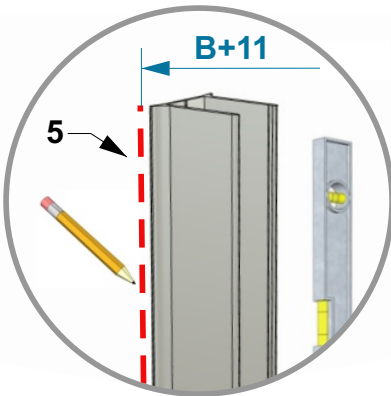
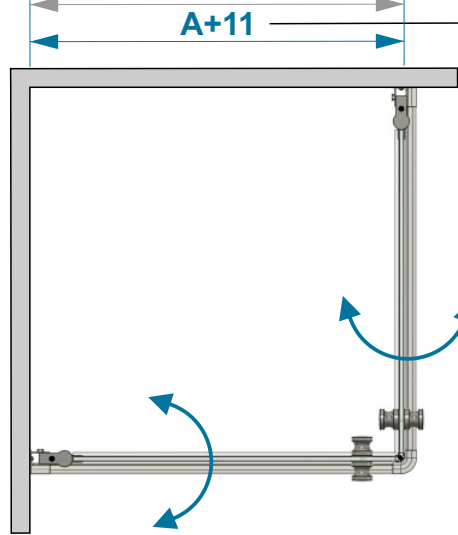

2.

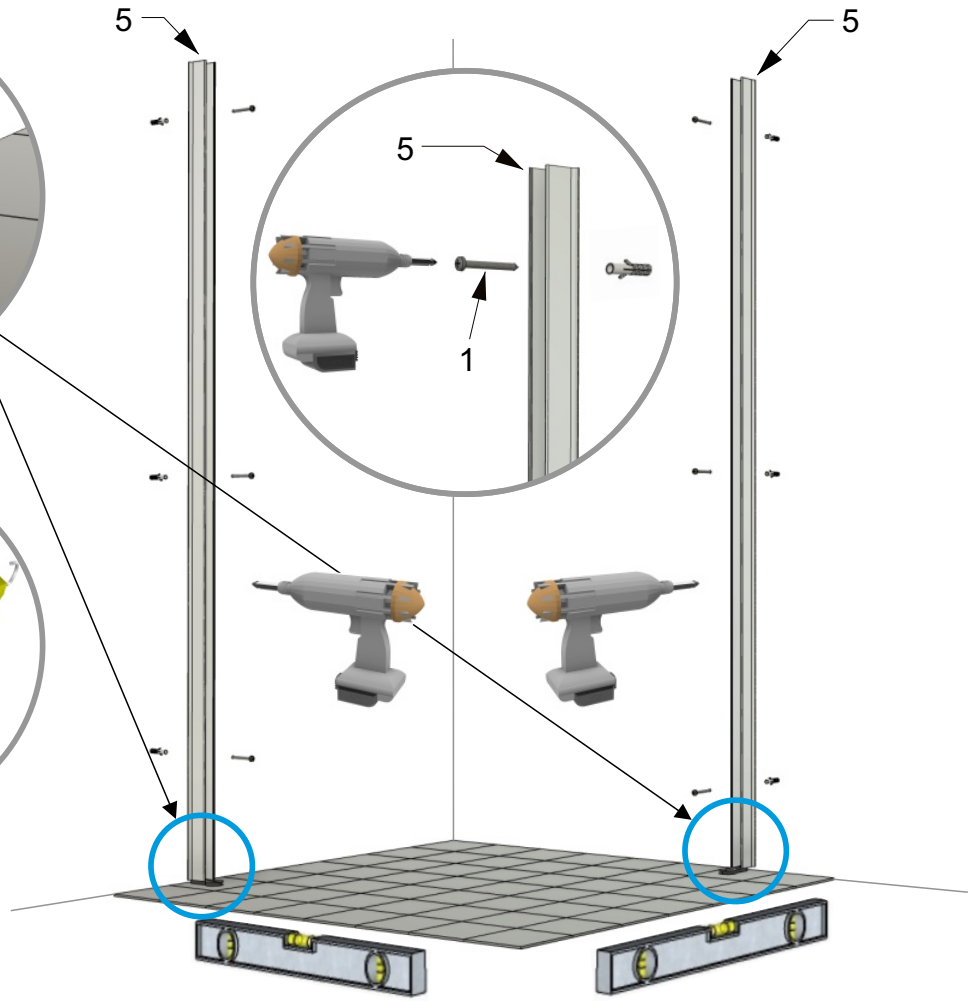
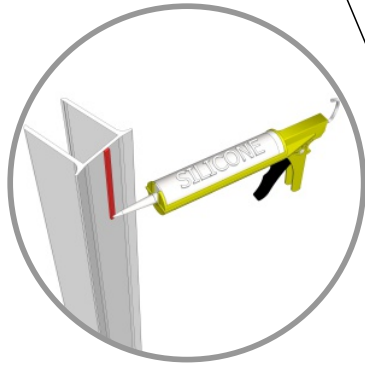
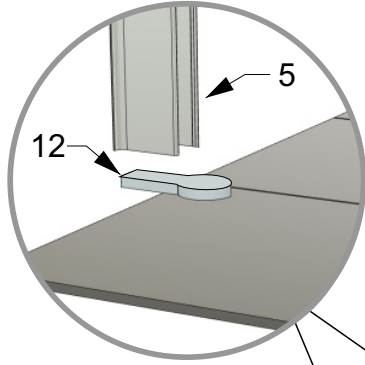
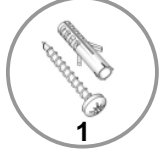
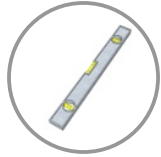

3. 2x

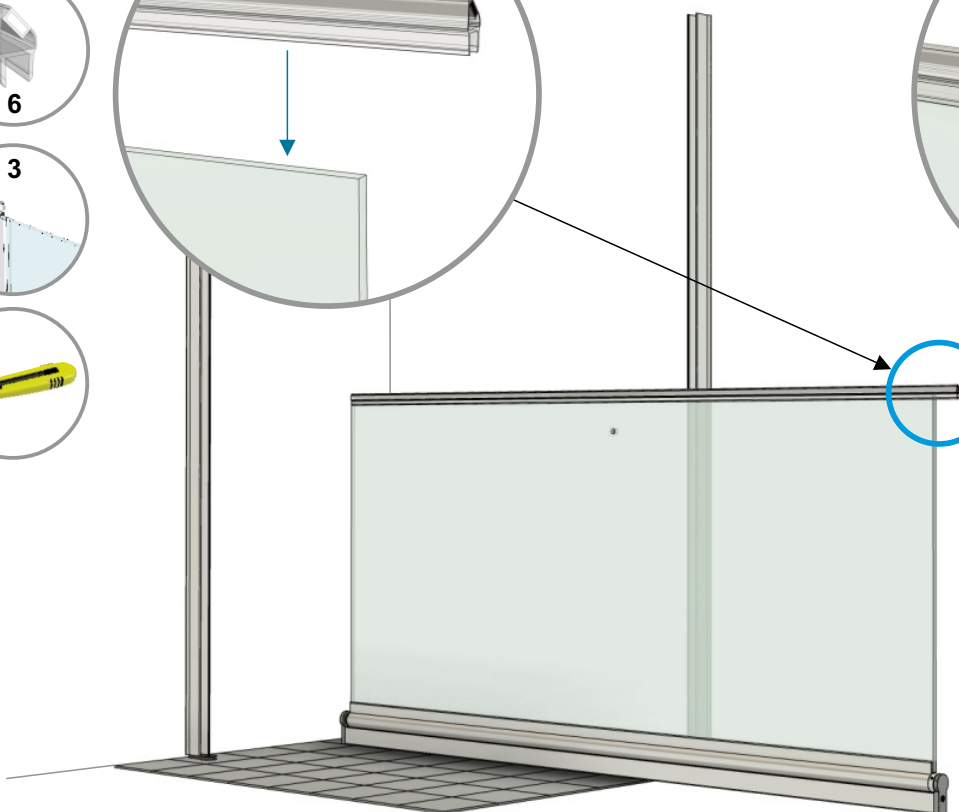
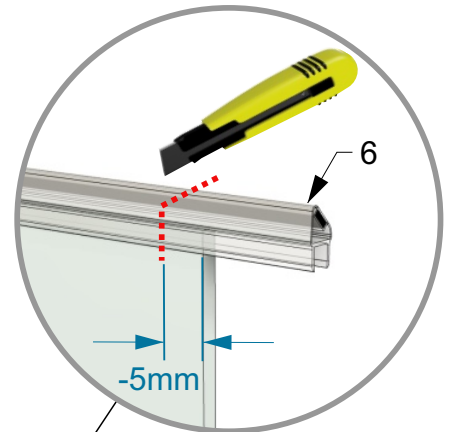
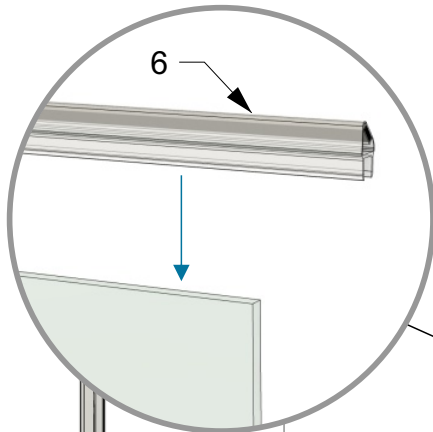
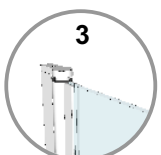
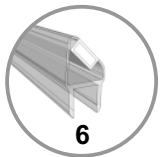

4. 2x

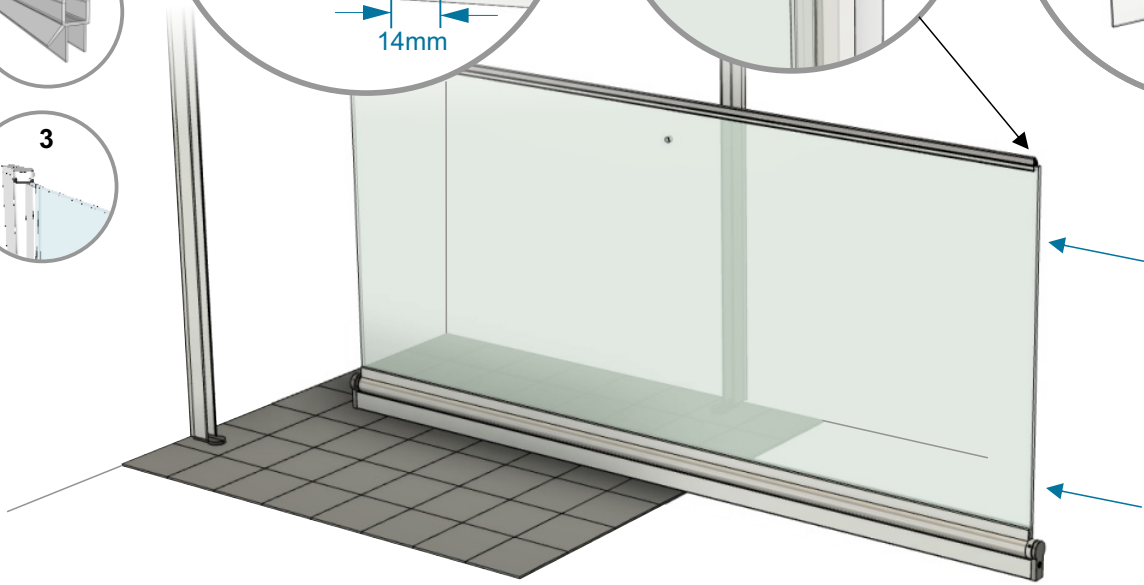
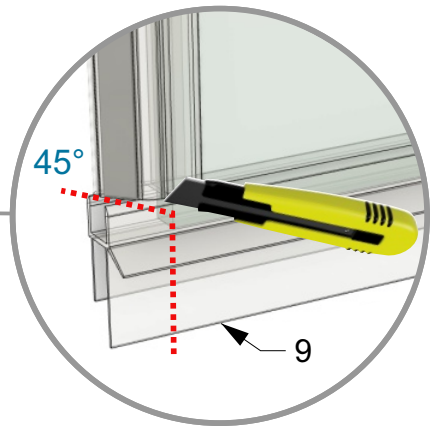
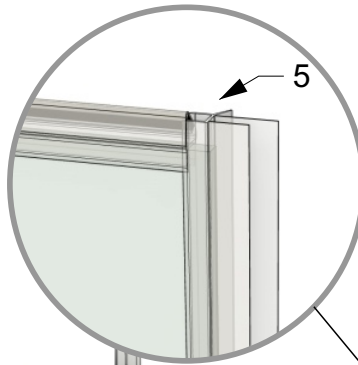
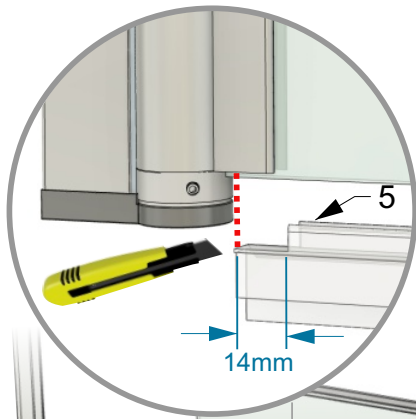

5.

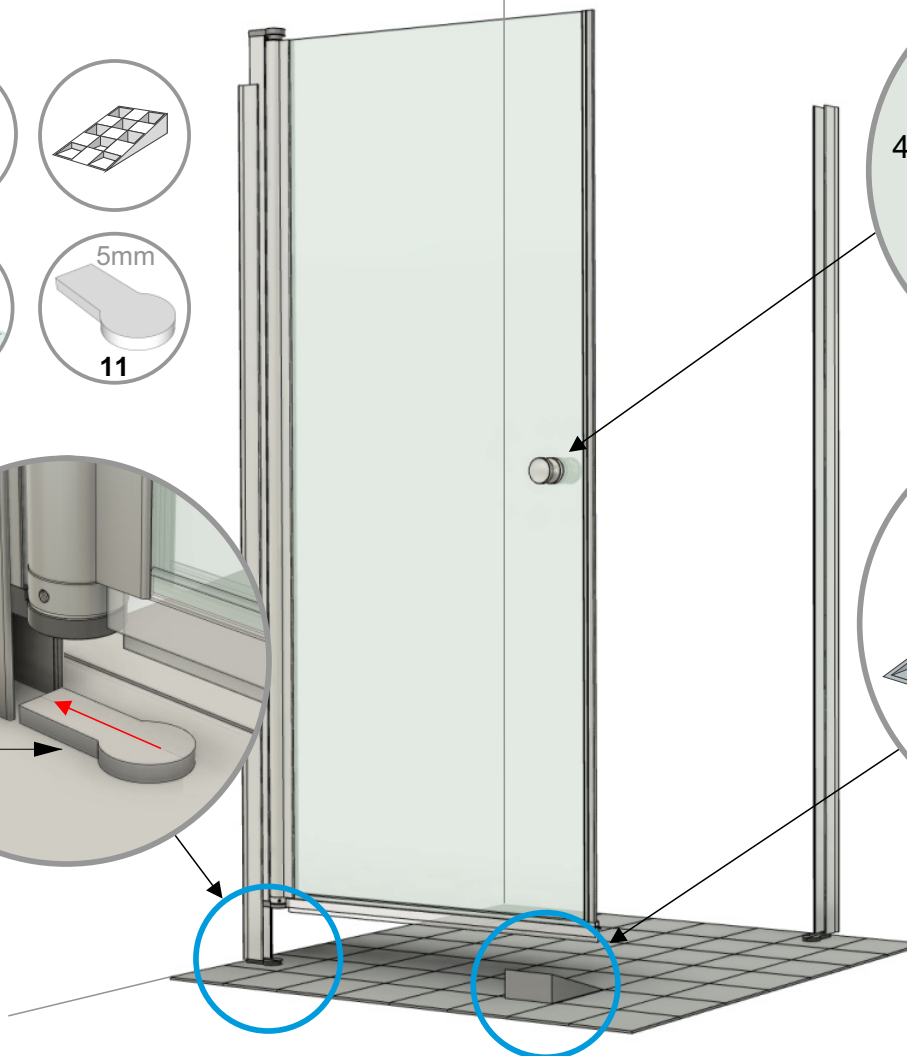
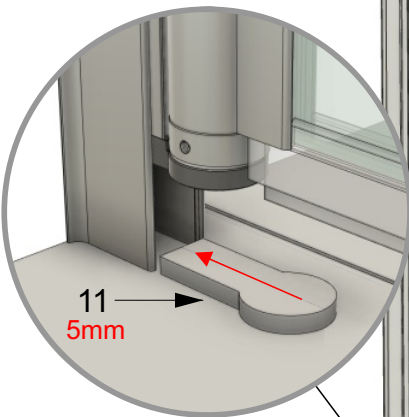
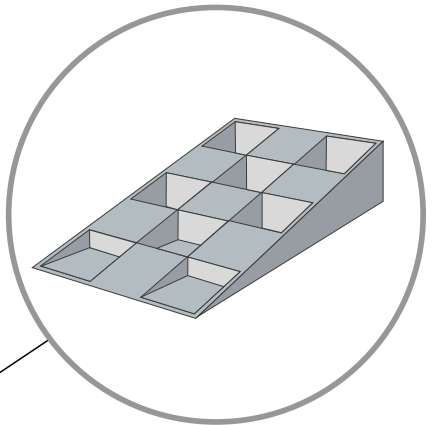
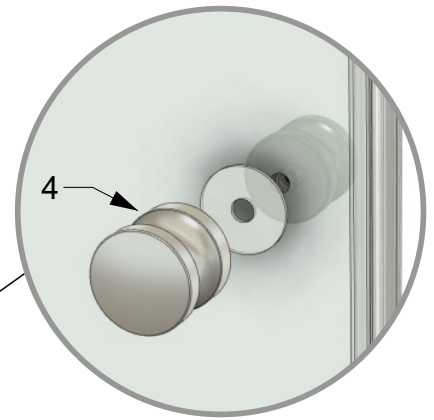
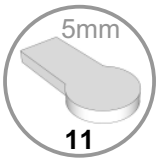
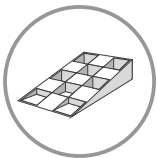

6.

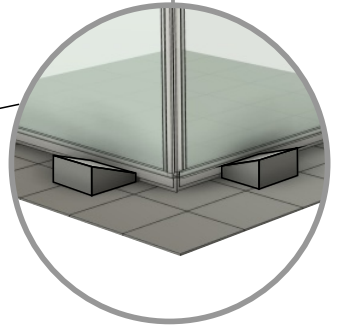
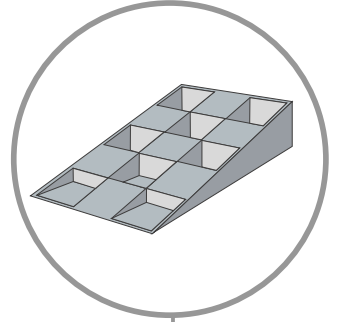
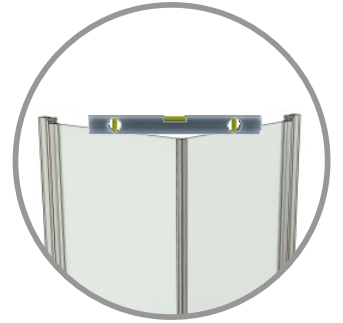
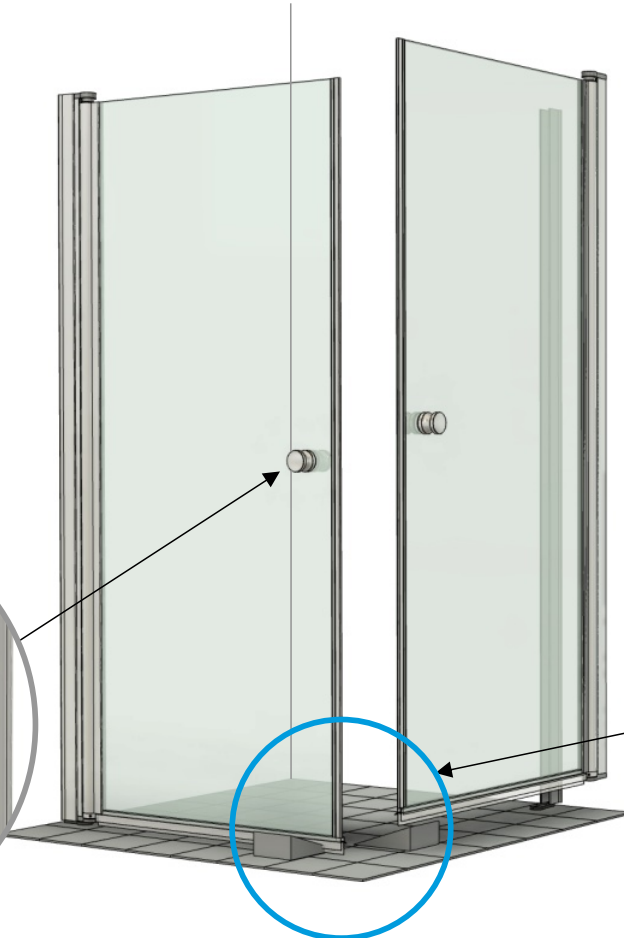
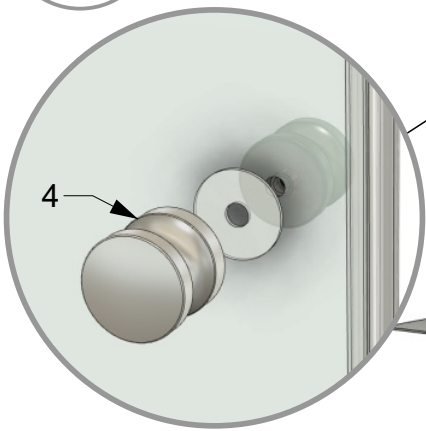
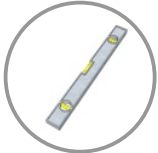
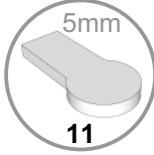
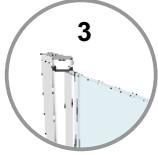
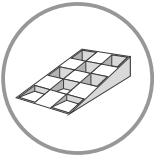
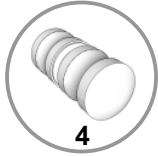

7.

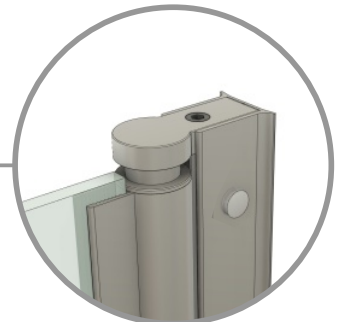
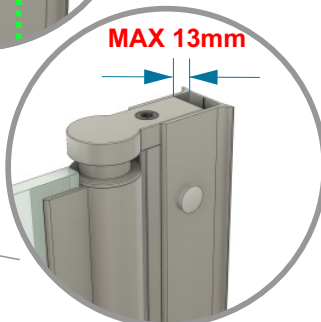
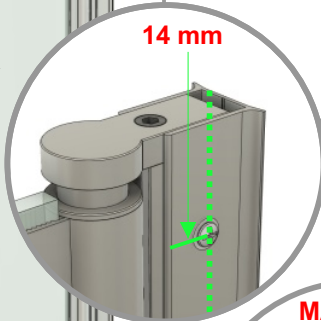
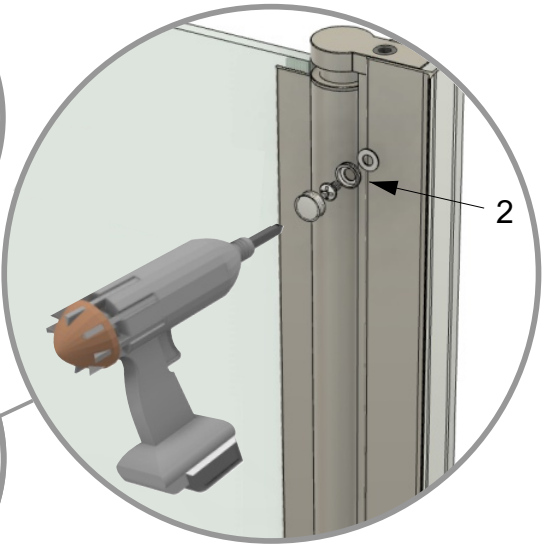
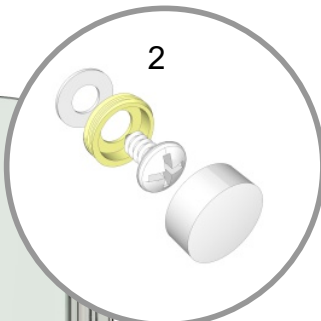
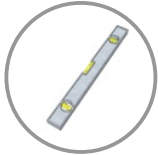
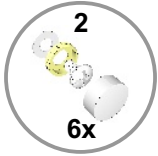

8.

