

ifö Compact 10

SE Monteringsanvisning

NO Monteringsanvisning

DE Montageanleitung

PL Instrukcja montażowa

LT Montavimo instrukcija

DK Monteringsvejledning

GB Assembly instructions

RU Инструкция по установке

EE Monteerimisjuhend

LV Montāžas norādījumi



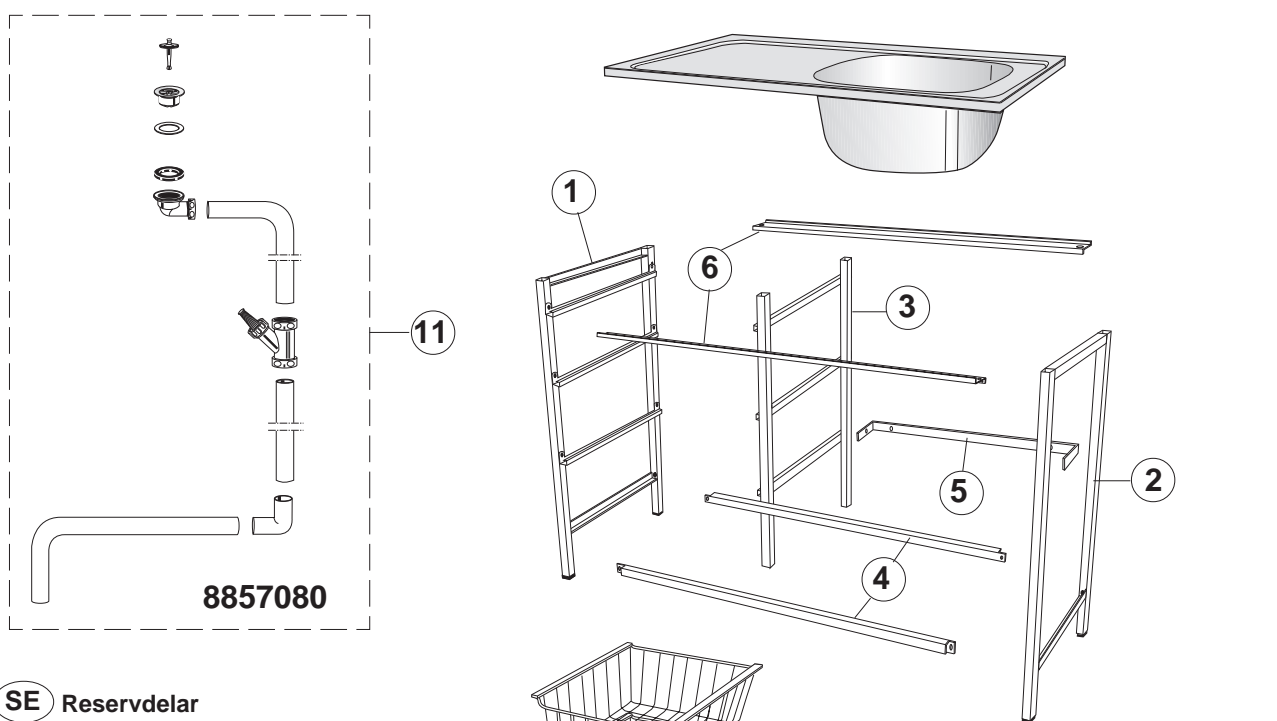

8857080

SE Reservdelar

- | | | |
|----|---------|--------------------------------|
| 1 | 0411530 | Gavel korgsida |
| 2 | 0411630 | Gavel |
| 3 | 0411830 | Mittsektion |
| 4 | 0412001 | Nedre stag |
| 5 | 0412201 | Väggfäste |
| 6 | 0412901 | Övre stag |
| 7 | 1710194 | Trådback |
| 8 | 1710170 | Skruv K6S M6x10 Fzb. |
| 9 | 1710172 | Skruv MC6LS BN 1206 M8x20 Fzb. |
| 10 | 1710174 | Insexnyckel (n=4) för M6 |
| 11 | 8857080 | Avloppsarrangemang kpl. |

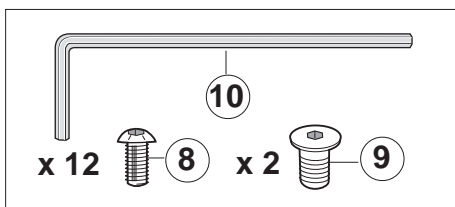
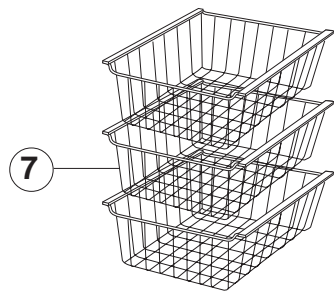

DK Reservedele

- | | | |
|----|---------|--------------------------------|
| 1 | 0411530 | Gavl kurvside |
| 2 | 0411630 | Gavl |
| 3 | 0411830 | Midtersektion |
| 4 | 0412001 | Nederste skinne |
| 5 | 0412201 | Vægbeslag |
| 6 | 0412901 | Øverste skinne |
| 7 | 1710194 | Trådkurv |
| 8 | 1710170 | Skrue K6S M6x10 Fzb. |
| 9 | 1710172 | Skrue MC6LS BN 1206 M8x20 Fzb. |
| 10 | 1710174 | Unbrakonøgle (n=4) til M6 |
| 11 | 8857080 | Afløbsarrangement kbl. |

NO Reservedeler

- | | | |
|----|---------|--------------------------------|
| 1 | 0411530 | Endestykke kurvsida |
| 2 | 0411630 | Endestykke |
| 3 | 0411830 | Midtseksjon |
| 4 | 0412001 | Nedre stag |
| 5 | 0412201 | Veggfeste |
| 6 | 0412901 | Øvre stag |
| 7 | 1710194 | Trådkurv |
| 8 | 1710170 | Skrue K6S M6x10 Fzb. |
| 9 | 1710172 | Skrue MC6LS BN 1206 M8x20 Fzb. |
| 10 | 1710174 | Unbrakonøkkell (n=4) for M6 |
| 11 | 8857080 | Avløpsarrangement, kopleing |

GB Parts

- | | | |
|----|---------|----------------------------------|
| 1 | 0411530 | Upright, basket side |
| 2 | 0411630 | Upright |
| 3 | 0411830 | Middle section |
| 4 | 0412001 | Lower strut |
| 5 | 0412201 | Wall attachment |
| 6 | 0412901 | Upper strut |
| 7 | 1710194 | Wire basket |
| 8 | 1710170 | Screw K6S M6x10 Fzb |
| 9 | 1710172 | Screw MC6LS BN 1206 M8x20 Fzb. |
| 10 | 1710174 | Socket key (n=4) for M6 |
| 11 | 8857080 | Waste pipe arrangement, complete |

DE Ersatzteile

- | | | |
|----|---------|--------------------------------------|
| 1 | 0411530 | Seitenteil (Korbseite) |
| 2 | 0411630 | Seitenteil |
| 3 | 0411830 | Mittelteil |
| 4 | 0412001 | Untere Verbindungsstangen |
| 5 | 0412201 | Wandbefestigung |
| 6 | 0412901 | Obere Verbindungsstangen |
| 7 | 1710194 | Drahtkorb |
| 8 | 1710170 | Schraube K6S M6x10 Fzb. |
| 9 | 1708000 | Schraube MC6LS BN 1206 M8x20 Fzb. |
| 10 | 1710174 | Innensechskantschlüssel (n=4) für M6 |
| 11 | 8857080 | Abflusvorrichtung komplett |

PL Części zapasowe

- | | | |
|----|---------|--------------------------------|
| 1 | 0411530 | Nóżki po stronie koszyków |
| 2 | 0411630 | Nóżki |
| 3 | 0411830 | Wspornik środkowy |
| 4 | 0412001 | Wsporniki dolne |
| 5 | 0412201 | Uchwyt mocujący do ściany |
| 6 | 0412901 | Wsporniki górne |
| 7 | 1710194 | Koszyki druciane |
| 8 | 1710170 | Śruba K6S M6x10 Fzb |
| 9 | 1708000 | Śruba MC6LS BN 1206 M8x20 Fzb. |
| 10 | 1710174 | Klucz imbusowy (n=4) do M6 |
| 11 | 8857080 | System odpływowy |

RU Запасные части

- | | | |
|----|---------|---------------------------------------|
| 1 | 0411530 | Стойка со стороны сеток |
| 2 | 0411630 | Стойка со стороны мойки |
| 3 | 0411830 | Промежуточная стойка |
| 4 | 0412001 | Нижняя перекладина между стойками |
| 5 | 0412201 | Перекладина для мойки |
| 6 | 0412901 | Верхняя перекладина между стойками |
| 7 | 1710194 | Сеточная корзина |
| 8 | 1710170 | Стяжной болт K6S M6x10 |
| 9 | 1708000 | Стяжной болт MC6LS BN 1206 M8x20 Fzb. |
| 10 | 1710174 | Ключ для монтажа (n=4 для M6) |
| 11 | 8857080 | Водоотводная труба в комплекте |

EE Varuosad

- | | | |
|----|---------|--------------------------------------|
| 1 | 0411530 | Korvidepoolne küljeosa |
| 2 | 0411630 | Küljeosa |
| 3 | 0411830 | Keskmine sektsioon |
| 4 | 0412001 | Alumine staag |
| 5 | 0412201 | Seinakinnitus |
| 6 | 0412901 | Ülemine staag |
| 7 | 1710194 | Korvashtlid |
| 8 | 1710170 | Kruvi K6S M6x10 Fzb. |
| 9 | 1708000 | Kruvi MC6LS BN 1206 M8x20 Fzb. |
| 10 | 1710174 | Kuuekandiline mutrivõti (n=4) M6'ile |
| 11 | 8857080 | Äravoolutoru, kompl. |

LT Atsarginės dalys

- | | | |
|----|---------|-----------------------------------|
| 1 | 0411530 | Galinis rėmas krepšio pusėje |
| 2 | 0411630 | Galinis rėmas |
| 3 | 0411830 | Vidurinė pertvara |
| 4 | 0412001 | Apatinis skersinis |
| 5 | 0412201 | Sieninis tvirtinimas |
| 6 | 0412901 | Viršutinis skersinis |
| 7 | 1710194 | Vielinis krepšys |
| 8 | 1710170 | Sraigtas K6S M6x10 Fzb. |
| 9 | 1708000 | Sraigtas MC6LS BN 1206 M8x20 Fzb. |
| 10 | 1710174 | Raktas (n=4) tinka M6 |
| 11 | 8857080 | Nutekėjimo mechanizmas |

LV Rezerves daļas

- | | | |
|----|---------|---|
| 1 | 0411530 | Grozū statīvs, sānu balsts |
| 2 | 0411630 | Sānu balsts |
| 3 | 0411830 | Balsta vidēja sekcija |
| 4 | 0412001 | Apakšējais savienojums |
| 5 | 0412201 | Sienas līste |
| 6 | 0412901 | Augšējais savienojums |
| 7 | 1710194 | Stieplu grozi |
| 8 | 1710170 | Skrūve K6S M6x10 Fzb |
| 9 | 1708000 | Skrūve MC6LS BN 1206 M8x20 Fzb. |
| 10 | 1710174 | Skrūvgriezis (n=4), paredzēts M6 |
| 11 | 8857080 | Kanalizācijas novadmehānisma komplekts. |

